

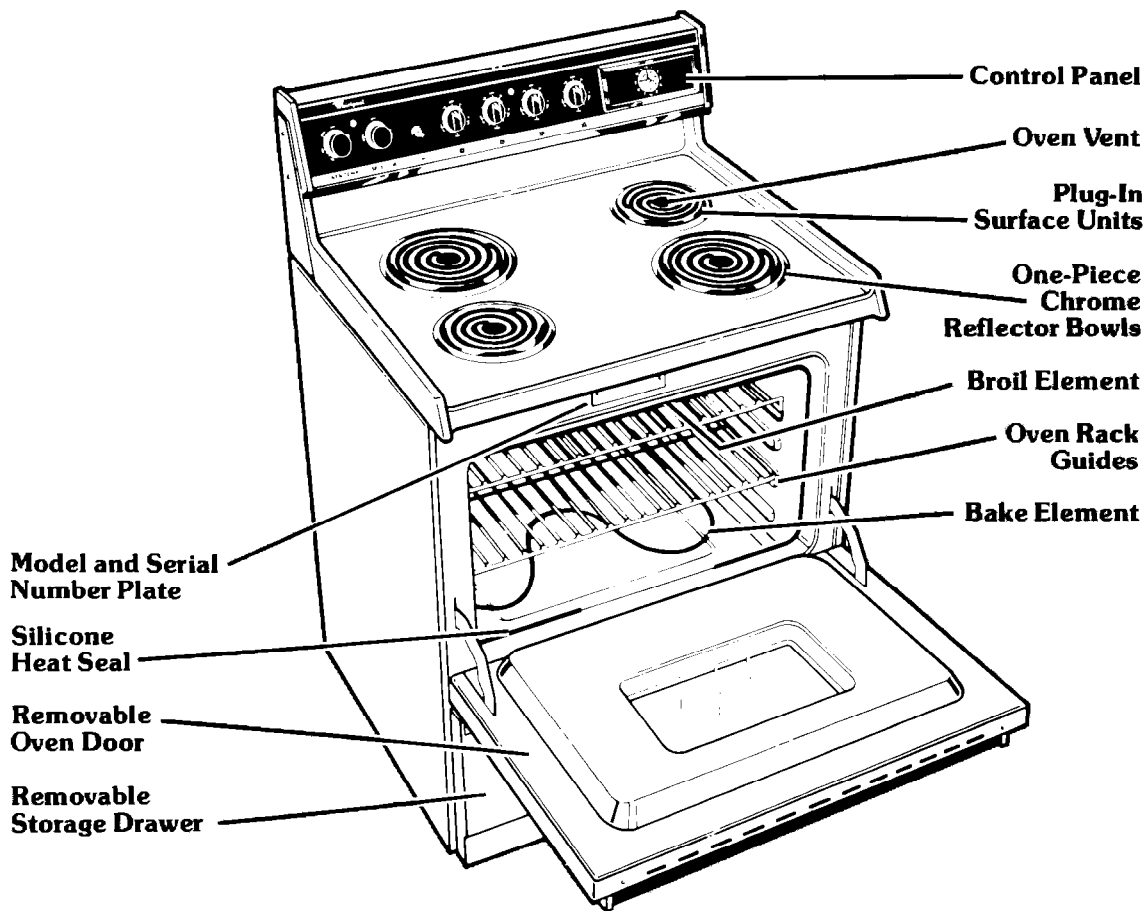

Whirlpool

FREE-STANDING ELECTRIC RANGES Models RJE-3100 and RJE-313P

USE AND CARE GUIDE



Copy Your Model and Serial Number Here

If you have questions or need to call for service, the service company will ask for your Model and Serial Numbers. Your new range has these numbers on a plate above the oven... just behind the top of the oven door. Copy the numbers in these spaces while you are thinking about it.

Keep this book in a handy place. Your warranty and sales slip should be kept with it.

_____ Model Number

_____ Serial Number

_____ Purchase and Installation Date

_____ Service Company and Phone Number

See Cooking Guide for important safety information.

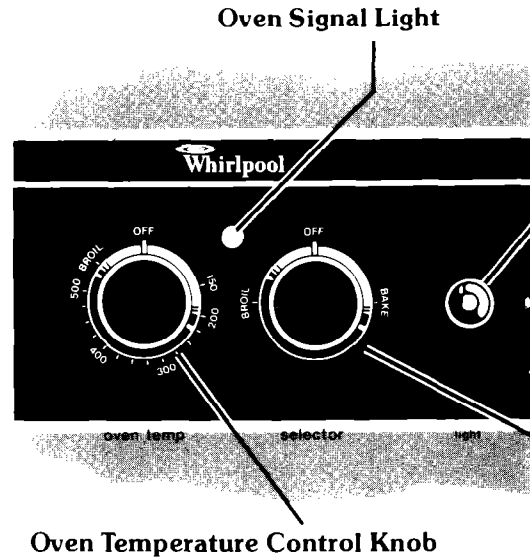
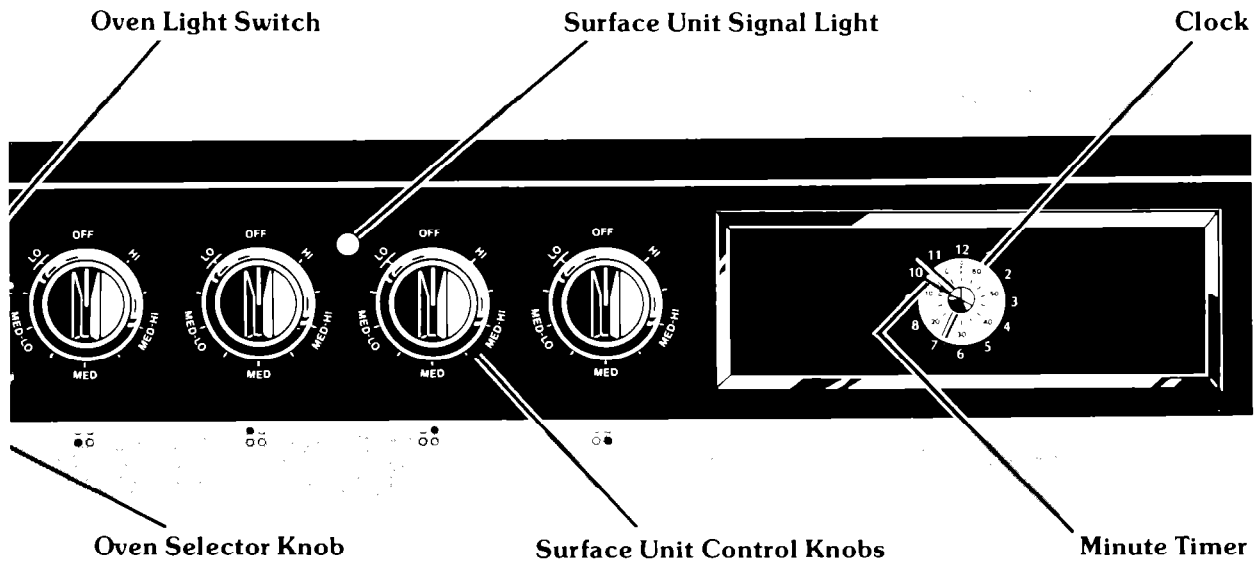

Table of Contents

	Page
BEFORE USING YOUR RANGE	3
USING THE SURFACE UNIT CONTROLS	4
USING THE OVEN CONTROLS	4
• Baking	4
• Broiling	4
• Variable Broil Feature	5
• Resetting the Oven Temperature Control Knob	5
SETTING THE CLOCK TO THE CORRECT TIME OF DAY	6
USING THE MINUTE TIMER	6
OVEN RACK POSITIONS	6
USING THE OVEN LIGHT	7
THE OVEN VENT	7
THE OPTIONAL ROTISSERIE	7
CLEANING AND CARING FOR YOUR RANGE	7
• Removing and Replacing Control Knobs	7
• Cleaning Under the Cooktop	9
• Removing the Oven Door	9
• Removing the Outer Oven Window	10
• Removing the Storage Drawer	10
• Cleaning Chart	11
IF YOU NEED SERVICE OR HELP	12
1. Before You Call for Service	12
2. If You Need Service	13
3. If You Have a Problem	13



Before using your range

IMPORTANT

This is the only fine print you'll find in this booklet. Please read it to be sure you use your range as it was meant to be used.

We build appliances to last, but we can't control how they are used. Before using it, you are personally responsible for making sure that it...

- is properly installed and leveled on a floor that will hold the weight, and in a well-ventilated room.
- is connected only to the right kind of outlet, with the right electric supply and grounding.
- is used only for jobs expected of home ranges.
- is out of the weather.
- is properly maintained.
- is **not** used by children or others who may not understand how it should be used.

SAFETY FIRST

- **Do not let children use or play with the range.**
- **Use your range only for the job it is intended to do.**
- **Read the "Cooking Guide" for important safety information. It also has other general hints for the care and use of your range.**
- **Read the Installation Instructions for complete information.**

Using the surface unit controls

The Surface Unit Control Knobs must be pushed in before turning them. This helps avoid turning them on accidentally when wiping off the Control Panel. And it helps keep small children from turning them on. **You must push in on them...then turn to the setting you want.**

A design by each knob tells which unit is turned on by that knob. (For example, | • | shows that the right front unit...the one closest to you on your right...will heat when you push in and turn that knob.)

The knob may be set anywhere between "HI" and "OFF." As you use your surface units, you will get used to the settings that match your pots, pans and favorite foods the best.

As a guide, the setting should cook at about the following heats:

HI — To start most foods cooking. To bring water to a boil.

MED-HI — To hold a rapid boil; to fry pancakes or chicken.

MED — To make gravy, puddings and icings; to cook large quantities of vegetables.

MED-LO — To keep food cooking after starting it at a higher setting.

LO — To keep food warm until ready to serve. You will notice that you can set the heat higher or lower within the LO band | $\frac{LO}{LO}$ | to help keep food at the temperature you want.

The Signal Light will glow whenever a Surface Unit is on. Be sure this light is off when you have finished cooking.

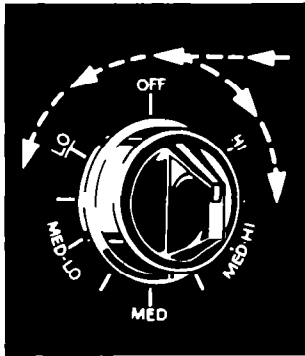

PUSH IN and turn to setting.

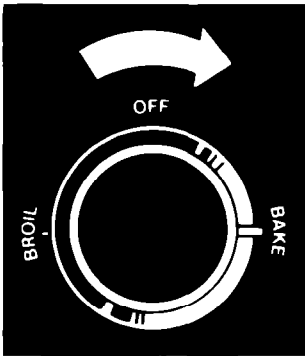

To bake, turn the Oven Selector Knob to BAKE.

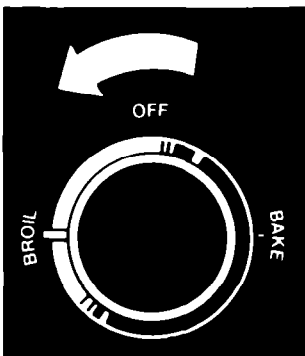

To broil, turn the Oven Selector Knob to BROIL.

Using the oven controls

Baking:

First—Follow the directions on page 6 for "Positioning Oven Racks."

Second—Turn the Oven Selector Knob to "BAKE."

Third—Turn the Oven Temperature Control Knob to the baking temperature you want. The Oven Signal Light will glow while the oven is heating. When this light goes off, the oven has heated to the temperature you set.

Fourth—Place food in oven. The heating elements turn off and on during baking to keep the oven at the temperature you set. The Oven Signal Light will glow when the heating elements are on.

Fifth—When the baking is done, turn both the Oven Temperature and Oven Selector Knobs to "OFF."

Broiling:

First—Follow the directions on page 5 for placing the meat at the right distance from the Broil Element.

Second—Turn the Oven Selector to "BROIL."

Third—Turn the Oven Temperature Control Knob to "BROIL" or turn it to a lower temperature (see "Variable Broil Feature," on page 5).

Fourth—Put the broiler pan on the oven rack.

Fifth—Keep the oven door open about four inches (10 cm). There is a stop in the hinges to hold it there. The Oven Signal Light will glow while the broil element is on.

Sixth—When you are through, turn both the Oven Temperature Control and the Oven Selector Knobs to "OFF."

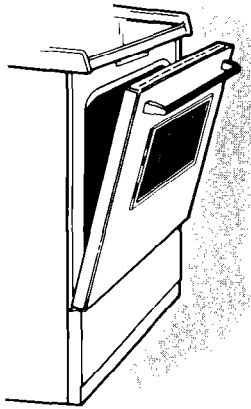

ALWAYS broil with the door open about 4 inches (10 cm).

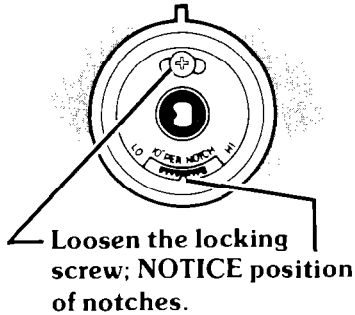

Loosen the locking screw; NOTICE position of notches.

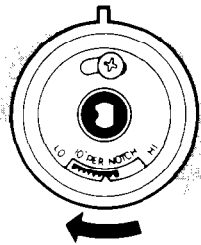

**Lower: move black part toward "LO."
One notch equals about 10°F (5°C).**

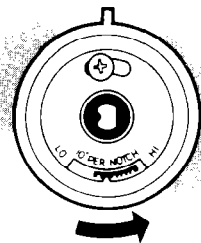

**Higher: move black part toward "HI."
One notch equals about 10°F (5°C).**

The following chart suggests broiling times and oven-rack positions for different kinds of meats when the Oven Selector Knob is set to **BROIL**.

Food	Description	Inches (cm) from top of food to Broil Element	Approximate Minutes	
			1st side	2nd side
Beef Steaks				
Rare	1" (2.5 cm)	3" (8 cm)	7-9	3-5
Medium	1" (2.5 cm)	3" (8 cm)	9-11	4-7
Well done	1" (2.5 cm)	3" (8 cm)	11-13	5-7
Beef Steaks				
Rare	1½" (4 cm)	4" -5" (10-13 cm)	13-15	6-8
Medium	1½" (4 cm)	4" -5" (10-13 cm)	17-19	8-10
Well done	1½" (4 cm)	4" -5" (10-13 cm)	19-21	14-16
Hamburgers	½" (1 cm)	3" (8 cm)	6-8	4-5
Lamb Chops				
Medium	1" (2.5 cm)	3" (8 cm)	6-8	4-5
Ham slice, precooked or tendered	½"-1" (1-2.5 cm)	3" (8 cm)	6-8	4-5
Canadian Bacon	½" (1 cm)	3" (8 cm)	6	4
Pork Rib or Loin Chop	¾"-1" (2-2.5 cm)	4" -5" (10-13 cm)	15	10
Chicken	2-3 lb. (1-1.5 kg)			
	cut in half	7" -9" (18-23 cm)	25-30	10-12
Fish	whole	3" (8 cm)	11-16	9-14
	fillets	3" (8 cm)	7-8	5-7
Liver	½"-¾" (1-2 cm)	3" (8 cm)	3	3
Frankfurters		4" -5" (10-13 cm)	6-7	4-5

Variable Broil Feature:

You might want to broil some foods slower than others. Broiling can be slowed down by setting a lower temperature on the Oven Temperature Control Knob instead of "BROIL." Using a lower temperature will cause the broil element to turn on and off during the broiling so that the food broils more slowly.

When the Oven Temperature Control Knob is on BROIL, the Broil Element heats all the time. Set the temperature lower and it heats some of the time. The lower the temperature setting, the shorter are the periods of heating.

NOTE: The Oven Selector must be in the "BROIL" position in order for the Broil Element to heat.

Resetting the Oven Temperature Control:

Does your new oven seem hotter or colder than your old oven? The temperatures in older ovens often shift very gradually, getting hotter or colder without the user really noticing the change. Your new oven is properly adjusted to provide accurate temperatures, but when compared to your old range, the new design may give you different baking results. If you think that the temperature setting on your range needs to be hotter or colder, you can adjust the Oven Temperature Control Knob by yourself.

To adjust the setting, first pull the Oven Temperature Control Knob straight off. On the back, just across from the locking screw, are a row of notches on the black part of the knob and one tooth on the chrome part.

To set your oven about 10°F(5°C) **cooler**, loosen the locking screw about two full turns and move the row of notches **one notch** closer to "LO." To set your oven about 10°F(5°C) **warmer**, move the row of notches **one notch** closer to "HI." Each notch equals about 10°F(5°C).

Tighten the locking screw and put the knob back on the control panel.

Clock and Timer Knob

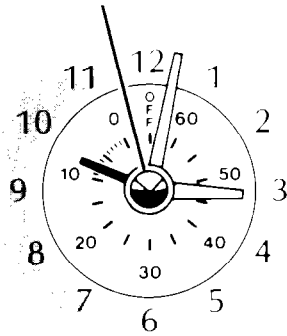

Minute Timer

Setting the clock to the correct time of day

1. Push in the Minute Timer Knob and turn it clockwise to set the hands to the correct time of day.
2. The Minute Timer hand will turn as you set the clock. When the clock is set, let the knob pop out. Then, while it is out, turn the Minute Timer hand **clockwise** to "OFF." If you push in on the knob when setting the Minute Timer, you will change the setting of the clock.

Using the Minute Timer

The small numbers inside the clock face are the minute markings. **Turn the knob in the center of the clock...don't push it in...to the number of minutes you want to time.** When the time you set is up, a buzzer will sound. Turn the hand to "OFF" to stop the buzzer.

The Minute Timer does not start or stop cooking. It only buzzes when the time you set is up. It can be used to time almost any cooking operation. It can even remind you of other things (like when to add the softener to the washer).

For the most accurate timing, turn the knob **past** the time you want. Then turn it back to the setting.

Oven rack positions

Your oven has two racks. Always put the racks where you want them to be **before you turn on the oven.**

To remove a rack, take hold of it on the front edge and pull it out until it stops. Then lift up the front edge and pull again. It will slide past the stops, out of the guides and out of the oven.

To put it back, fit the back corners into the guides at each side of the oven and slide it in, **keeping the front tilted up until the rack passes the stops in the rack guides.**

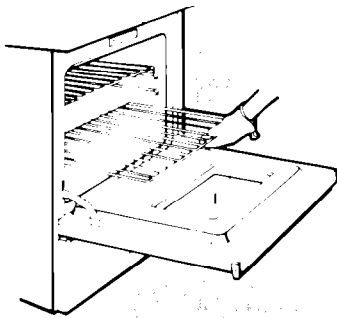

To remove rack, pull forward until rack stops, lift front and pull.

For:	Place Rack:
Baking	On the second or third rack guide from the top... so food is in the center of the oven.
Broiling	So food is about the distance from the broil element suggested in the broiling timetable under "Using the Oven Controls."
Roasting LARGE cuts of meat	On the bottom rack guides.
Roasting SMALLER cuts of meat	So food is in the center of the oven.

When baking, always leave at least 1½ to 2 inches (4-5 cm) of air space between the sides of a pan and other pans and the oven wall for air circulation.

For best results, get additional information on placing pans, cookie sheets and other utensils from the "Cooking Guide."

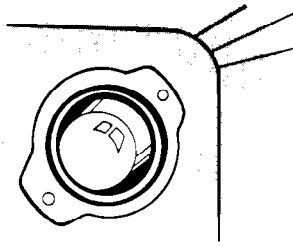

Replace with a 40-watt
APPLIANCE bulb.

Using the oven light

To turn on the oven light, push the oven light switch. Push it again to turn off the oven light.

To replace the oven light bulb:

1. Turn the electric power off at the main power supply.
2. Remove the light bulb from the socket.
3. Replace the bulb with a 40-watt **appliance** bulb (designed to stand up to oven heat) available at most grocery, variety and hardware stores.

The oven vent

There is an oven vent under the right rear surface element. When the oven is on, heated air will escape through it. A vent is needed for air circulation in the oven during baking. You can cook on this surface unit while the oven is on. A warm pan of food will stay warm on this unit while the oven is on. It may be warm enough to melt butter, too.

Do not try to save heat or energy by blocking the vent. Poor baking can result. Plastic utensils may melt if they are over the vent while the oven is on.

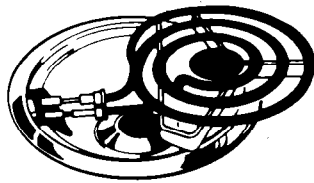

The optional rotisserie

If you would like a rotisserie with your oven, you can order a kit from your dealer. Easy installation instructions come with the kit.

Cleaning and caring for your range

Your range is designed to be easy to clean. You will usually wipe off spills and spatters when they happen, but you will sometimes want to clean under and behind the control knobs and surface units. This section will tell you how to remove those, and what to use when cleaning.

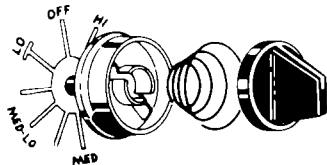

Pull knob and trim ring straight out. Remember how the spring goes.

Removing and replacing surface unit control knobs:

1. Be sure the control knobs are set to "OFF."
2. Pull straight out on the black knobs.
3. If the control has a chrome trim ring, pull it straight out.
4. Wash the knobs (and trim rings) in warm, sudsy water.
5. Replace the trim rings first. **If the control spring was removed, put it back exactly as shown on the left...small end first.**
6. Hold the black knob so it points to "OFF." Push it straight back on.

Removing and Replacing Oven Control Knobs:

1. Be sure the knobs are set to "OFF"
2. Pull each knob straight off.
3. Wash the knobs in warm, sudsy water.
4. The knobs are not interchangeable. Make sure you put the **adjustable Oven Temperature Control Knob** on the right place, and the **nonadjustable** Oven Selector Knob on the other.

Removing surface units and reflector bowls:

1. First, be sure the Surface Unit Controls are all "OFF" and that the surface units are cool.
2. See where the surface units plug into the range? Lift each surface unit about an inch (2.5 cm) at the edge away from the plug-in (receptacle). Pull the unit straight away from the plug-in. **Do not wash surface units; they will burn themselves clean during normal use.**
3. Lift out the reflector bowls.

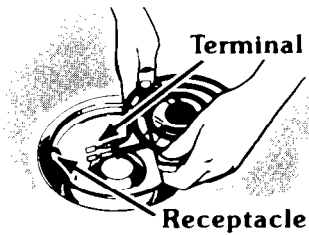

To remove surface unit, lift and pull straight out.

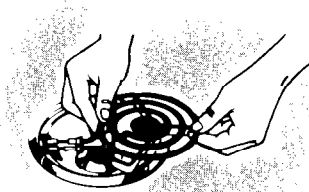

Hold surface unit level when replacing.

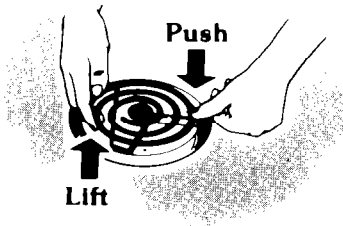

NOTE: Reflector bowls help catch spillovers and reflect heat back to the pot or pan on the surface unit. When they are kept clean, they reflect heat better and look new longer.

If a reflector bowl turns blue or gold, some of the pans you are using may not be flat enough. Or some may be too large for the surface unit. In both cases, some of the heat that is meant to go into or around a pan goes down and heats the reflector bowl. This extra heat can discolor it.

Do not line the reflector bowls with aluminum foil. Use of foil liners could cause shock or fire hazard.

Replacing reflector bowls and surface units:

1. Be sure the surface unit controls are on "OFF."
2. Put the reflector bowls back into their places. Make sure you can see the plug-ins (receptacles) for the surface units through the square hole in the side of each bowl.
3. Hold the surface unit level with the prongs (terminals) pointing at the plug-in.
4. With the prongs started in the plug-in, start pushing in on the surface unit. At the same time, lift a little on the side of the surface unit that's by the plug-in.
5. Make sure the surface-unit prongs are pushed into the plug-in as far as they will go. The surface unit will fit into the reflector bowl and be level when everything has been done right.

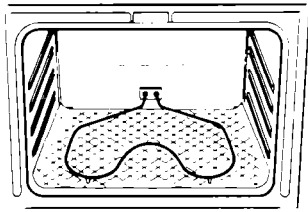

Foil should be flat on the bottom so should the feet on the element.

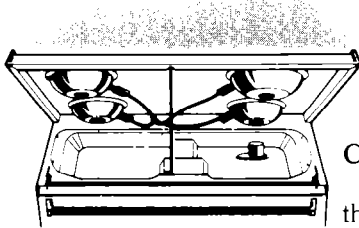

Prop up the top with support rod.

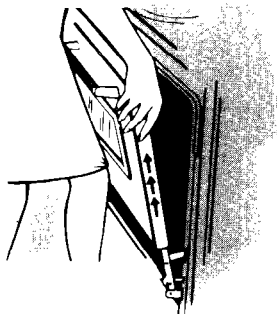

Pull straight with the angle of part-open door.

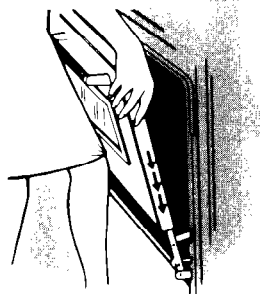

Push down evenly.

Easier cleaning with aluminum foil:

Oven cleaning can be a chore when spillovers bake onto the bottom of the oven. Use aluminum foil so you can just throw it away with the spillovers. You can use the heavy-duty 18-inch (45 cm) aluminum foil found in most grocery stores. Or you can order an aluminum foil kit (Part Number 241430) from your Whirlpool Dealer.

1. When cutting the foil, make sure it is long enough to cover the bottom with enough left over to start up both sides.
2. Make sure the bake element is cool. Lift it far enough to raise its feet from the bottom of the oven. (You may have to remove the oven rack.)
3. Slide the foil sheet under the bake element. Make sure it is centered and long enough to start up the sides.
4. When you put the bake element back down, make sure all the feet rest solidly on the foil and that the foil is smoothed out across the bottom of the oven. If the feet on the element are not solidly on the foil, the oven may not bake properly.

Cleaning under the cooktop:

To clean the area under the cooktop, lift the front of the cooktop at the center. Raise the swing-up rod to hold it. (Be sure the tip of the rod is in the notch in the cooktop.) Use warm soapy water and a sponge or cloth. Scouring powders or any other abrasive cleaner may harm porcelain-enamel finishes and can scratch chrome.

Be careful not to raise the cooktop so high that it touches the control console. And don't drop it. Dropping the cooktop can chip or crack a hard porcelain finish, or damage side panels and surface units.

Removing the oven door:

Removing the oven door may make it easier to clean the oven. To remove the door, first open it to the first stop (about 4 inches or 10 cm). Take hold of both sides of the door near the top; then lift it **at the same angle it is in**.

With the door off, you will notice how the ends of the hinges slide into slots at the bottom corners of the door. To put the door back on, fit both bottom corners of the door over the ends of the hinges. Push the door down evenly, so neither corner gets ahead of the other. When it reaches the bottom, you can close the door. A safety latch will hold the door open until it is on correctly.

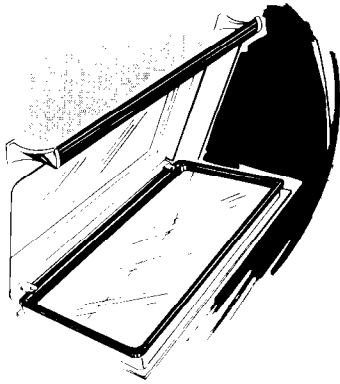

Remove screws; swing out top. Lift up at bottom.

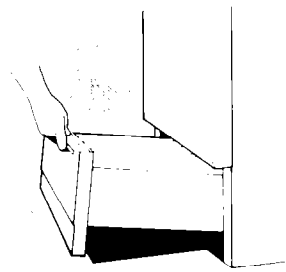

Pull to stop. Lift; pull again.

Removing the outer oven window:

If your oven door has a window **instead of the full-width black glass**, the outer glass and frame can be removed for cleaning between the two. It is held on by screws at the top, and tabs hidden at the bottom. **Do not try to take apart an oven door with full-width glass.**

1. With the oven door closed, remove the screws from the top of the outer window frame.
2. Tip the frame out about two inches (5 cm) from the door. (The frame and glass are one piece, so don't worry about them coming apart.)
3. Lift up on both sides of the frame to pull the tabs out of the slot at the bottom of the window opening.

To replace the frame and glass, line up the bottom of the frame with the opening in the door.

1. Tilt the frame so that the tabs fit into the slot at the bottom of the window opening.
2. Tilt the frame as far as you can and push down.
3. Push the frame in the rest of the way and replace the screws.

Removing the storage drawer:

The drawer below your oven is meant to store pots and pans. **Never keep anything in there that will burn or melt.**

You may want to remove the drawer for cleaning under the range. Pull it straight out until it stops. Lift the front and pull some more to get it over the stop. Now slide it out until it stops again. Lift the drawer away from the range until it slips out of the guides.

To put it back, fit the side rails at the back of the drawer into both guides on the range. Push it closed while lifting the front to get past the stops.

PART	WHAT TO USE	HOW TO CLEAN
Outside of appliance	Soft cloth, warm soapy water	<ul style="list-style-type: none"> • Wipe off regularly when range is cool.
	Nylon or plastic scouring pad for stubborn spots	<ul style="list-style-type: none"> • Do not allow food containing acids (such as vinegar, tomato, lemon juice or milk) to remain on surface. Acids will remove the glossy finish. • Do not use abrasive or harsh cleansers.
Surface units	No cleaning required	<ul style="list-style-type: none"> • Spatters or spills will burn off. • Wipe off excessive spills with damp cloth when surface unit is cold. • Do not immerse in water.
Control knobs and chrome rims	Warm, sudsy water and bristle brush	<ul style="list-style-type: none"> • Wash, rinse and dry well. • Do not soak.
Chrome reflector bowls	Automatic dishwasher or warm, soapy water or plastic scrubbing pad	<ul style="list-style-type: none"> • Clean frequently. • Wash with other cooking utensils. • Do not use harsh abrasives.
Aluminum broiler pan and grid	Warm, soapy water or soapy steel wool pads	<ul style="list-style-type: none"> • Wash with other cooking utensils.
Control panel	Warm, soapy water	<ul style="list-style-type: none"> • Wash, rinse and dry with soft cloth.
Oven racks	Warm, soapy water or soapy steel wool pads	<ul style="list-style-type: none"> • Wash, rinse and dry. Use steel wool pads for stubborn areas.
Oven door glass	Warm, soapy water or plastic scrubbing pad	<ul style="list-style-type: none"> • Make certain oven is cool. Wash, rinse and dry well with soft cloth.
	Commercial glass cleaner	<ul style="list-style-type: none"> • Follow directions provided with cleaner.
Standard oven	Warm, soapy water or soapy steel wool pads	<ul style="list-style-type: none"> • Remove door for easier access. • Place newspaper on floor to protect floor surface.
	Commercial oven cleaners	<ul style="list-style-type: none"> • Follow directions provided with the oven cleaner. • Rinse well with clear water. • Use in well ventilated room. • Do not allow commercial oven cleaner to contact the heating elements, oven seal, or exterior surfaces of the range.

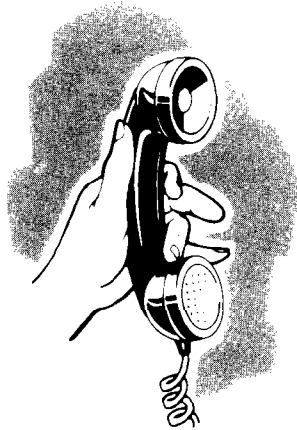

IF YOU NEED SERVICE OR HELP, WE SUGGEST YOU FOLLOW THESE THREE STEPS:

1. Before you call for service*:

If your range does not seem to be operating properly, check the following before calling for service.

If nothing operates:

- Is the range plugged into an operating outlet or wired into a live circuit with the proper voltage? (See **Installation Instructions**.)
- Have you checked the main fuse or circuit-breaker box?

If the oven will not operate:

- Is the Oven Selector Knob turned to a setting (BAKE or BROIL)?
- Is the Oven Temperature Control Knob turned to a temperature setting?

If surface units will not operate:

- Have you checked the main fuse or circuit-breaker box?
- Are surface units plugged in all the way?
- Do the control knobs turn?

If surface-unit Control Knob or Knobs will not turn:

- Is the spring put in correctly, as shown on page 7 in the "Cleaning and Caring for your Range" Section?
- Did you push in before trying to turn?

If cooking results aren't what you expect:

- Is the range level?
- Are you using pans recommended in the **Cooking Guide**?
- If baking, have you allowed 1½ to 2 inches (4-5 cm) on all sides of the pans for air circulation?
- Does the oven temperature seem too low or too high? See page 5, "Resetting Your Oven Temperature Control Knob."
- Have you preheated the oven as the recipe calls for?
- Are the pans the size called for in the recipe?
- Are you following a tested recipe from a reliable source?
- Do the cooking utensils have smooth, flat bottoms?
- Do the cooking utensils fit the surface unit being used?

See the **Cooking Guide** for more information on cooking problems and how to solve them.



2. If you need service* :

If your WHIRLPOOL® appliance ever needs service anywhere in the United States, help is just a phone call away...to your nearest Whirlpool franchised TECH-CARE® service representative.

Whirlpool maintains a nationwide network of franchised TECH-CARE service companies to fulfill your warranty and provide after-warranty service and maintenance to keep your WHIRLPOOL appliance in peak condition.

You'll find your nearest TECH-CARE service company listed in your local telephone book Yellow Pages under Washers/Dryers—Repairing or Servicing. **Should you not find a listing, dial free, the Whirlpool COOL-LINE® service assistance telephone number (800) 253-1301.**

When calling from:

Michigan	(800) 632-2243
Alaska & Hawaii	(800) 253-1121

If you move...

To make sure that your appliance is correctly installed and to insure its continued satisfactory operation, please telephone your nearest TECH-CARE® service company for installation or to get the name of a qualified installer. (Installation cost will, of course, be paid by you.)

Helpful hints...

You can help your TECH-CARE service representative give you faster service if you include the model and serial number of your appliance when requesting service. Also, retain your sales slip and warranty to verify your warranty status.

Remember...

Your TECH-CARE service representative is specially trained in the expert repairing and servicing of your WHIRLPOOL appliances. He can help you maintain the quality originally built into your WHIRLPOOL appliance. So why not take the time, now, to look up his telephone number and jot it down in the space provided on the cover.

3. If you have a problem* :

Call Whirlpool Corporation in Benton Harbor at the COOL-LINE service assistance telephone number (see Step 2) or write:

Mr. Stephen E. Upton, Vice President
Whirlpool Corporation
Administrative Center
2000 U.S. 33 North
Benton Harbor, Michigan 49022

* If you must call or write, please provide: your name, address, telephone number, type of appliance, brand, model, serial number, date of purchase, the dealer's name, and a complete description of the problem. This information is needed in order to better respond to your request for assistance

Notes



Notes



FSP is a registered trademark of Whirlpool Corporation for quality parts. Look for this symbol of quality whenever you need a replacement part for your Whirlpool appliance. FSP replacement parts

will fit right and work right, because they are made to the same exacting specifications used to build every new Whirlpool appliance.



Whirlpool
Home Appliances



Benton Harbor, Michigan. Automatic Washers, Clothes Dryers, Freezers, Refrigerator-Freezers, Ice Makers, Dishwashers, Built-in Ovens and Surface Units, Ranges, Microwave Ovens, Compactors, Room Air Conditioners, Dehumidifiers, Central Heating and Air Conditioning Systems.

Quality. Our way of life.